

10-FRAME LANGSTROTH BEE HIVE

CONSTRUCTION DETAILS FOR 3/4" THICK LUMBER

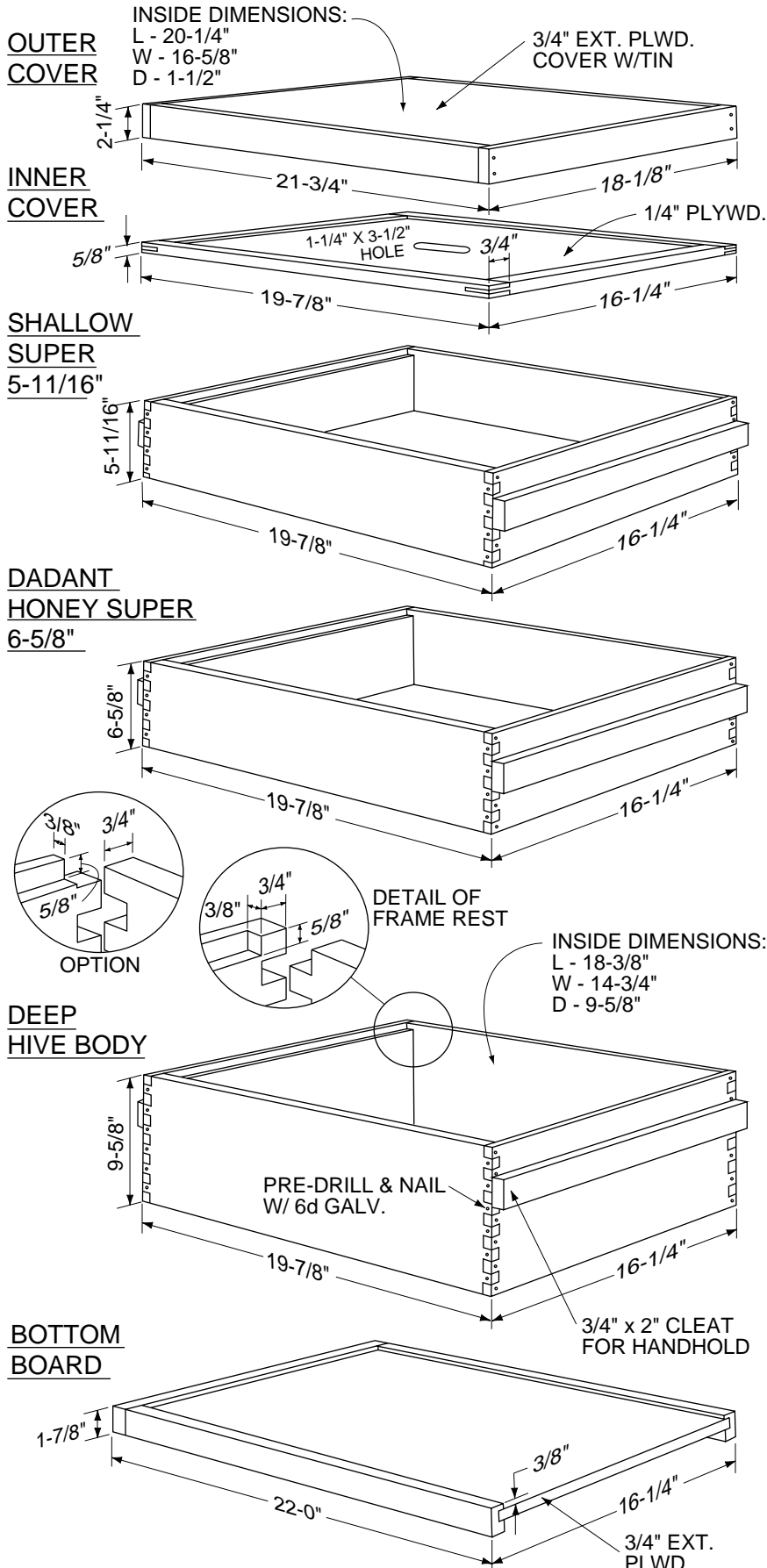

The species of wood used to make a beehive can vary depending upon what is available in your area. The minimum thickness should not be less than 3/4". If you are using standard dimensional lumber, you can use 1x6 (3/4" x 5-1/2") for the shallow super, 1x8 (3/4" x 7-1/4") for the medium super and 1x12 (3/4" x 11-1/4") for the deep hive body.

Start by cutting the boards to length. For fronts and backs, cut them a smidgen over 16-1/4". For sides, cut a smidgen over 19-7/8". At this point, follow the steps described on how to make a box joint from the PDF 'Box Joint' files.

Now that you have the joint cut and the boards cut to finished size, cut the 5/8" x 3/8" rabbet on the 16-1/4" boards stopping just short of the box joint pin at each end. (Chisel these square after the boards are assembled). Note detail of frame rest at left. Pre-drill holes for nails in each pin.

Assemble boxes with glue and nail each pin with a 6d galv. nail. Attach 1x2 handholds with screws and glue. Attach metal rabbets on the frame rest notch. Fill any holes and paint both outside and inside and top and bottom edges with two coats of paint.